

P STYLE POLE BURY DEPTH CHART

DIM "A"	3' 6"	4'	5'
POLE LENGTH	8	15P4	20P4
	10		25
	12		

SELECT POLE LENGTH. READ BURY DEPTH ("A") AT TOP OF APPROPRIATE COLUMN.

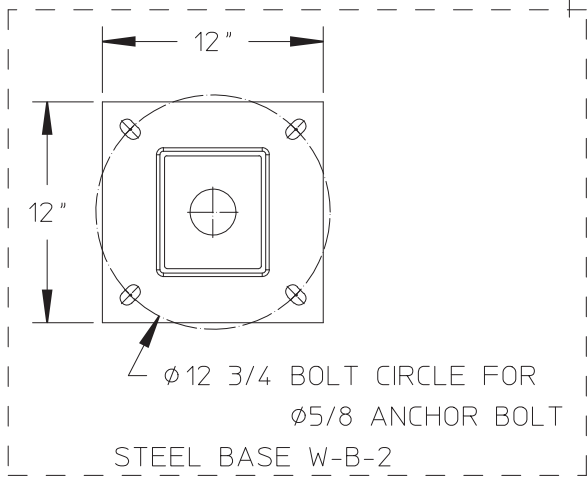

6" X 5-1/8" P AND PV SIDE MOUNT STRAIGHT POLE SPECIFICATION



**6" x 5-1/8" P and PV SIDE MOUNT STRAIGHT POLE**

**BUILDING A PART NUMBER**

MODEL	HEIGHT	TYPE	TEXTURE	CONFIGURATION	FINISH*
<b>TW2</b>	<b>25</b>	<b>PV</b>	<b>R</b>	<b>SM</b>	<b>BK**</b>

**TW2** –  
6"x 5-1/8"

8  
10  
12  
15P4  
20P4  
25

**P** –  
DIRECT  
BURIAL  
  
**PV** –  
ANCHOR  
BOLT

**R** –  
ROUGH  
  
**S** –  
SMOOTH

**SM** –  
SIDE MOUNT

**FINISHES STANDARD**

- **BKT** Black Textured
- **BK** Black
- **VG** Verde Green
- **PGT** Park Green Textured
- **PG** Park Green
- **ABZT** Architectural Medium Bronze Textured
- **ABZ** Architectural Medium Bronze
- **SI** Swedish Iron
- **DBT** Dark Bronze Textured
- **DB** Dark Bronze
- **OWGT** Old World Gray Textured
- **OWG** Old World Gray

**FINISHES CUSTOM**

- **WHT** White Textured
- **WH** White
- **CV** Copper Vein
- **WBK** Weathered Black
- **WBR** Weathered Brown
- **CD** Cedar
- **RT** Rust
- **OI** Old Iron
- **TT** Two Tone
- **CM** Custom Match

\*Base and metal parts (non-fixture)  
\*\*Default color if none is chosen

**Specifications – For TimberWood Architectural Laminated Wood Light Poles**

- 1.0 General:** TimberWood Architectural Laminated Wood Light Poles shall be of materials, size, shapes, styles, patterns and fabrication as specified herein and as shown on JH Baxter detail drawings.
- 2.0 Lumber:** Coast region Douglas Fir only for direct bury, (Port Orford Cedar or Alaskan Yellow Cedar for above ground use only). L1 laminating grade for strength and appearance is used on all exposed wide faces. L2 or L2 dense is used for interior laminations. Grades are described in current WCLIB Grading Rules.
- 3.0 Laminating Requirements:** Architectural Laminated Wood Light Poles shall be laminated with adhesives meeting or exceeding the exterior durability performance requirements of the most recent revision of American National Standard ANSI / AITC A190.1-2007.
- 4.0 Surface Finish, Appearance & Tolerance:** Open defects such as knotholes exceeding 1/2" in diameter or wane exceeding 1/4" x 12" shall be filled with wood filler for surfaced four faces with edges eased to 3/8" radius. For rough, textured four sides, knots will be exposed. Tolerances shall be from +0 to -1/4" in width and depth.
- 5.0 Preservative Treatment:** Architectural Laminated Wood Light Poles will be treated with 6% pentachlorophenol borne in light hydrocarbon solvent in conformance with AWPA Standards to a minimum net retention of 0.60 pounds per cubic foot of penta.
- 6.0 Trademark:** Each Architectural Laminated Wood Light Poles shall be branded to indicate Manufacture-Month-Year at 18" above intended ground line.
- 7.0 Wrapping:** Architectural Laminated Wood Light Poles will be individually wrapped.
- 8.0 Embedment:** As required by local codes and soil conditions. Designed by others. Refer to form no. SL-1281 for recommendations.
- 9.0 Top Protection:** Metal cap must be installed unless fixture is top mounted.
- 10.0 Incising:** All Architectural Laminated Wood Light Poles will be incised on all four sides to 1/2" in depth from butt to 16" above indicated ground mark (P poles) or 12" from butt if mounted in steel base (PV). Incising adds durability to treated Douglas Fir.