

ONE WAY CROSS ARM CHART

DIM "C"	6'	8'
ARCH ASSEMBLY	A88-6S	A88-8S
DIM "B"	20.25"	27"
DIM "D"	36"	51"

P STYLE POLE BURY DEPTH CHART

DIM "A"	3'6"	4'	4'6"
POLE LENGTH	12	15	20

SELECT POLE LENGTH. READ BURY DEPTH ('A') AT TOP OF APPROPRIATE COLUMN.

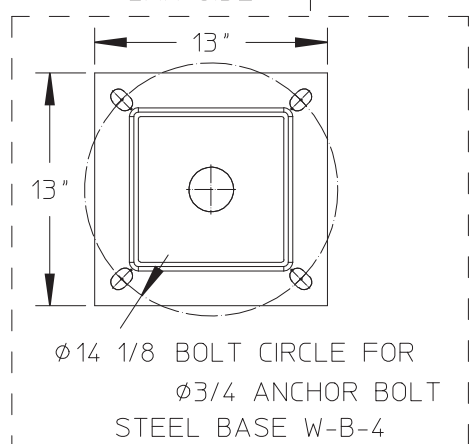

8" X 8" P AND PV PRONGHORN STRAIGHT POLE SPECIFICATION WITH ONE WAY CROSS ARM



8" x 8" P AND PV PRONGHORN STRAIGHT POLE WITH ONE WAY CROSS ARM

BUILDING A PART NUMBER

MODEL	HEIGHT	TYPE	TEXTURE	ONE WAY CROSS ARM	FINISH*
PH2	15	PV	R	6	BKT**

PH2 –
8"x 8"

12
15
20

P –
DIRECT
BURIAL

PV –
ANCHOR
BOLT

R –
ROUGH

S –
SMOOTH

6'
8'

STANDARD FINISHES¹

- **BKT** Black Textured
- **WHT** White Textured
- **PGT** Park Green Textured
- **ABZT** Architectural Medium Bronze Textured
- **DBT** Dark Bronze Textured

¹Smooth finishes are available upon request

CUSTOM FINISHES

- **OI** Old Iron
- **RT** Rust
- **WBR** Weathered Brown
- **CD** Cedar
- **WBK** Weathered Black
- **TT** Two Tone

STERNBERG SELECT FINISHES

- **VG** Verde Green
- **SI** Swedish Iron
- **OWGT** Old World Gray Textured

*Base and metal parts (non-fixture)
**Default color if none is chosen

Specifications – For TimberWood Architectural Laminated Wood Light Poles

- 1.0 General:** TimberWood Architectural Laminated Wood Light Poles shall be of materials, size, shapes, styles, patterns and fabrication as specified herein and as shown on JH Baxter detail drawings.
- 2.0 Lumber:** Coast region Douglas Fir only for direct bury, (Port Orford Cedar or Alaskan Yellow Cedar for above ground use only). L1 laminating grade for strength and appearance is used on all exposed wide faces. L2 or L2 dense is used for interior laminations. Grades are described in current WCLIB Grading Rules.
- 3.0 Laminating Requirements:** Architectural Laminated Wood Light Poles shall be laminated with adhesives meeting or exceeding the exterior durability performance requirements of the most recent revision of American National Standard ANSI / AITC A190.1-2007.
- 4.0 Surface Finish, Appearance & Tolerance:** Open defects such as knotholes exceeding 1/2" in diameter or wane exceeding 1/4" x 12" shall be filled with wood filler for surfaced four faces with edges eased to 3/8" radius. For rough, textured four sides, knots will be exposed. Tolerances shall be from +0 to -1/4" in width and depth.
- 5.0 Preservative Treatment:** Architectural Laminated Wood Light Poles will be treated with 6% pentachlorophenol borne in light hydrocarbon solvent in conformance with AWPA Standards to a minimum net retention of 0.60 pounds per cubic foot of penta.
- 6.0 Trademark:** Each Architectural Laminated Wood Light Poles shall be branded to indicate Manufacture-Month-Year at 18" above intended ground line.
- 7.0 Wrapping:** Architectural Laminated Wood Light Poles will be individually wrapped.
- 8.0 Embedment:** As required by local codes and soil conditions. Designed by others. Refer to form no. SL-1281 for recommendations.
- 9.0 Top Protection:** Metal cap must be installed unless fixture is top mounted.
- 10.0 Incising:** All Architectural Laminated Wood Light Poles will be incised on all four sides to 1/2" in depth from butt to 16" above indicated ground mark (P poles) or 12" from butt if mounted in steel base (PV). Incising adds durability to treated Douglas Fir.